

SMART CUT® 6025-A

AUTOMATIC & MANUAL PRECISION SAW

OPERATING MANUAL



Technical Specifications
Model: SMART CUT 6025 - AUTO

- **Blade Feed:** Automatic/Manual
- **Blade Movement:** Continuous, Pulse
- **Blade Dimensions (mm):** 200 x 12.7 x 0.8
- **Blade Speed (RPM):** 500-3000 (Customizable)
- **Table Dimensions (W x D, mm):** 368 x 424
- **DC Motor:** 600W
- **Power Supply:** 110/220V AC, 50-60Hz, 1 Phase

Included Accessories:

- **Diamond Blade:** ●
 - **Alumina Blade:** ○
 - **SiC Blade:** ○
 - **Fast Cam Locking Vises:** ●
 - **Vertical Clamping Vise:** ○
 - **X-Feed Fixture:** ○
 - **Cutting Vise (for screws, bars, etc., in longitudinal direction):** ○
 - **Cutting Fluid:** ○
- Standard
○ Optional

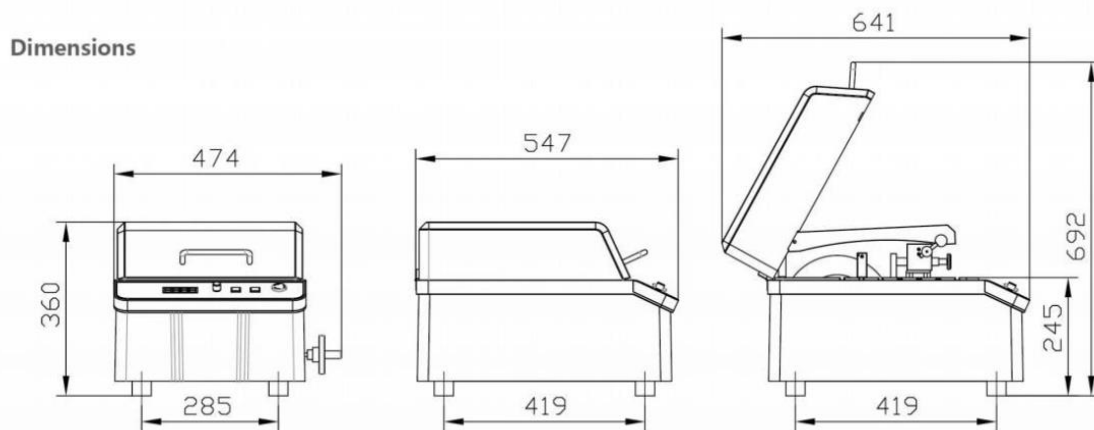

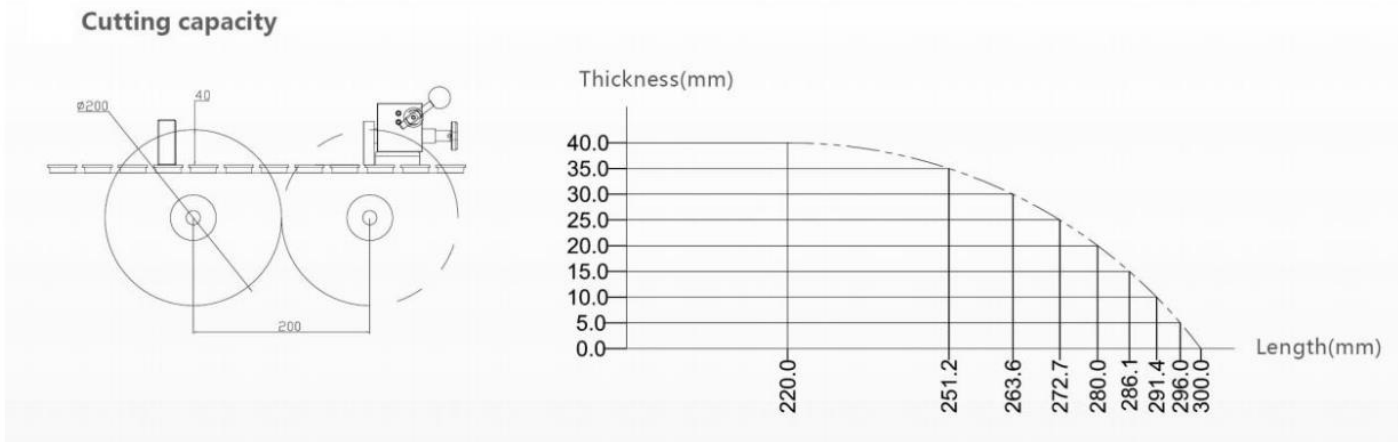

STEP-BY-STEP INSTRUCTIONS:

1. **Powering On:** Once the device is powered on, the start page will appear on the screen. To proceed, click any blank area on the screen to enter the main interface (the device's software interface).

SOFTWARE INTERFACE OVERVIEW:



1. **Y Position:** Displays the relative position (coordinate value) of the Y-axis motion in automatic mode.
2. **Moving Speed:** Indicates the speed at which the Y-axis moves without cutting in automatic mode. The speed is adjustable between 0-10mm/s.
3. **Cutting Speed:** Shows the Y-axis cutting speed in automatic mode during linear cutting, adjustable between 0-10mm/s.
4. **Feeding Distance:** Represents the feeding distance (0-5mm adjustable) of the Y-axis in pulse cutting mode, based on the set cutting speed in automatic mode.
5. **Complete:** Reflects the set cutting length and progress of the cutting process in automatic mode.

Mechanical Key Function Analysis:



- **Automatic Mode (Move Forward):** Click to move the Y-axis forward in automatic mode.
- **Automatic Mode (Move Backward):** Click to move the Y-axis backward in automatic mode.
- **START Button:** Click to start cutting in automatic mode.
- **STOP Button:** Click to stop cutting in automatic mode.
- **Emergency Stop Button:** Press this button to immediately stop the device, cutting, and power supply to the panel.

Magnetic Switch and Self-Locking Switch:

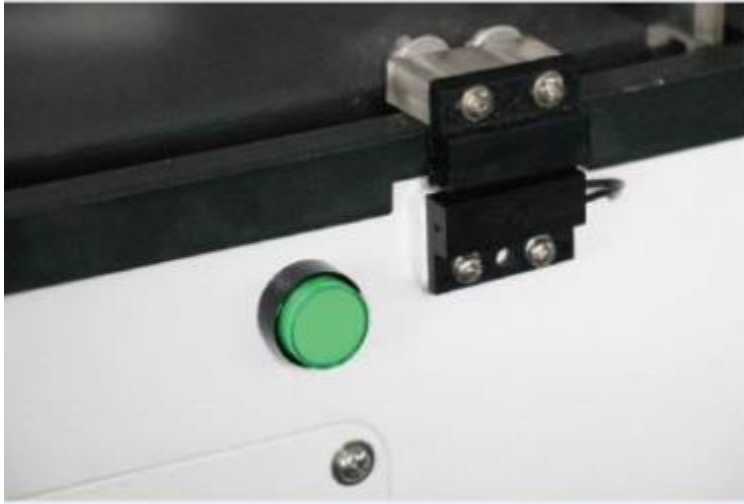

- **Magnetic Switch:** When the green self-locking switch is turned off, the two half-black magnetic switches are not activated, preventing the device from starting.
- **Self-Locking Switch:** When the green self-locking switch is turned on, the two half-black magnetic switches are activated, allowing the device to start, with or without the suction system.

In manual mode, the sample is cut by rotating the handwheel at a constant speed.

Features

- Dual cutting modes: automatic and manual
- Adjustable Y-axis positioning
- Customizable cutting speeds and feed rates
- User-friendly software interface
- Emergency stop button for safety
- Versatile blade compatibility for various materials

Safety Precautions

- Ensure the machine is properly grounded before use.
- Always wear safety goggles and gloves during operation.
- Do not attempt to service the machine while it is running.
- Always perform a dry run to test setup before cutting actual materials.
- Keep hands and loose clothing away from moving parts.

2. Machine Setup

Proper setup and installation are essential to ensure the SMART CUT 6025 Auto operates safely and efficiently. Follow the steps carefully to prepare the machine for use.

Unpacking and Installation

First, inspect the packaging for any visible damage before removing the machine. Use care when lifting the machine, and ensure you have at least two people assisting if it is heavy. Once removed, verify that all components listed in the manual, such as the blade, vises, and power cord, are included. Place the machine on a stable, level surface capable of supporting its weight, ensuring the area is clear of obstructions and well-ventilated. The machine should not be positioned on soft or uneven surfaces to avoid instability during operation.

Power Connection

Connect the power cord to a grounded outlet matching the machine's voltage requirements (110/220V AC, 50-60Hz, 1 Phase). Once the connection is secure, switch on the power using the main power switch. The machine will power up, and the start screen will appear on the display.

Assembly Instructions

Next, attach the blade securely to the spindle using the provided fixtures. Make sure the blade is aligned correctly and tightly secured to avoid any wobbling during operation. Once the blade is set, install the appropriate vise (Fast Cam Locking Vise, Vertical Clamping Vise, etc.) and clamping tools to hold the workpiece. Ensure the vise is properly aligned and tightened to prevent movement of the material during cutting.

Positioning the Workpiece



Place the material to be cut onto the work table, ensuring it is aligned with the cutting blade. Secure the workpiece using the clamping tools to hold it tightly in place. Double-check that the material is properly positioned before starting the cutting process. Make sure the workpiece is firmly held to prevent any shifting during cutting.

3. Software Overview

The software interface of the SMART CUT 6025 Auto provides users with a comprehensive set of tools to manage and control the machine's cutting processes. It allows you to adjust cutting parameters, monitor progress, and optimize the cutting operation based on material requirements and cutting conditions.

Main Interface

- **Start Page:**
When the machine is powered on, the system will display the start page. This initial screen serves as the gateway to the main software interface and provides quick access to the operational settings and controls.
- **Accessing the Main Interface:**
Simply **tap any blank area of the start screen** to enter the main software interface. The main interface is where you can view, adjust, and control various machine parameters to suit your cutting needs.
- **Software Display:**
The main interface provides a real-time view of various critical cutting parameters, including:
 - **Y-axis position:** The current position of the cutting blade.
 - **Cutting speed:** The speed at which the blade cuts through the material.
 - **Feed rate:** The rate at which the material is fed into the cutting blade.
 - **Blade movement:** Visual indicators showing whether the blade is moving in continuous or pulse mode.
- **Progress Monitoring:**
The interface also displays a cutting progress bar or indicator that shows how much of the cutting process has been completed. This allows users to track the operation in real time and make adjustments if necessary.

Key Functions and Parameters

The software interface provides a number of key functions and adjustable parameters to control the machine's cutting process. These settings are essential for achieving the best cutting results, depending on the material type and desired finish.

1. **Y Position:**
 - **Purpose:** Adjust the Y-axis position to set the starting point of the cut and to manage the depth of the cut during operation.
 - **Function:** In **automatic mode**, the Y-axis will adjust based on the settings configured in the software. The user can manually adjust the Y-position as needed to ensure the correct cutting depth.
 - **Importance:** Accurate Y-axis positioning is essential for controlling cutting precision, especially when working with materials requiring specific depths or when performing intricate cuts.

2. Moving Speed:

- **Purpose:** Set the speed at which the Y-axis moves when no cutting action is taking place. This setting is particularly useful for repositioning the blade or moving between cuts.
- **Range:** The moving speed is adjustable between **0-10mm/s** and can be customized to suit the specific requirements of the operation.
- **Importance:** The moving speed should be set to a value that ensures safe and efficient repositioning of the blade without compromising the quality of the cut.

3. Cutting Speed:

- **Purpose:** This parameter controls the speed at which the blade moves through the material during cutting.
- **Range:** Cutting speed is adjustable from **0-10mm/s** and can be tailored for different materials.
- **Importance:** The cutting speed is a crucial factor that affects the quality of the cut and the longevity of the blade. Softer materials generally allow for faster cutting speeds, while harder materials may require slower cutting speeds to prevent excessive wear or heat buildup.

4. Feeding Distance:

- **Purpose:** In **pulse cutting mode**, the feeding distance defines the distance the material is moved after each pulse of cutting action.
- **Range:** This parameter is adjustable from **0-5mm**.
- **Importance:** The feeding distance must be set appropriately to match the material thickness and desired cut quality. A smaller feeding distance allows for finer, more controlled cuts, while a larger feeding distance can increase cutting efficiency for thicker materials.

5. Complete:

- **Purpose:** This parameter displays the total cutting length and progress of the cutting operation in **automatic mode**.
- **Function:** It provides a visual progress bar or percentage, indicating how much of the cut has been completed and how much remains.
- **Importance:** Monitoring the progress of the cutting operation is essential for ensuring that the cut is proceeding as planned. This feature helps prevent over-cutting or under-cutting, ensuring precise results.

Customization Options

The SMART CUT 6025 Auto's software allows for a high degree of customization, enabling users to tailor the cutting process to meet the specific needs of their materials and cutting objectives.

- **Blade Speed (500-3000 RPM):**

The software allows you to adjust the **blade speed** to match the material's hardness and the desired cutting precision. Faster blade speeds are ideal for cutting softer materials, while slower speeds are more appropriate for harder materials that require more precision or heat dissipation.

- **Customization:** Select the appropriate RPM within the range of **500-3000 RPM** based on material specifications, cutting speed, and desired blade life.

- **Feed Rate Adjustment:**

The software enables you to modify the **feed rate** (the speed at which the material is fed into the blade) for more controlled cutting. A higher feed rate is useful for quicker cuts with softer materials, while a lower feed rate is better for delicate or harder materials.

 - **Customization:** Set the feed rate within the range of **0-10mm/s**, depending on the cutting requirements of the material.
- **Cutting Length Control:**

The **cutting length** can be customized to set how far the blade will travel before stopping or reversing. This allows you to perform cuts of specific lengths and repeat cuts without needing to manually reposition the machine.

 - **Customization:** The cutting length can be easily adjusted in the software, offering flexibility for multiple cutting tasks or batch operations.
- **Material-Specific Settings:**

The software allows you to configure cutting parameters based on the material being processed, ensuring that each cutting operation is optimized for the best performance.

 - **Customization:** Choose from predefined settings for common materials, or manually adjust parameters for unique or non-standard materials.
- **Preset Profiles:**

For recurring tasks, you can create and save preset profiles for different materials, cutting speeds, feed rates, and blade types. This streamlines the setup process for future cutting operations and reduces the likelihood of errors in parameter settings.
- **Real-Time Adjustments:**

During the cutting operation, users can make **real-time adjustments** to parameters such as cutting speed, feed rate, and blade position to optimize performance. This is particularly useful in cases where the material or cutting conditions change during the process.

4. Operating Instructions

Proper operation of the SMART CUT 6025 Auto ensures that the machine performs efficiently and produces high-quality cuts. Follow these detailed instructions for a safe and effective cutting process, whether you are using automatic or manual mode.

Turning On the Machine

1. **Press the Power Button:**

Locate the power button on the control panel and press it to turn the machine on. Wait for the system to boot up.
2. **Start Screen Display:**

Upon powering up, the machine's start screen will appear on the display. This screen serves as the gateway to the main interface.

3. Enter Main Interface:

Tap anywhere on the start screen to proceed to the main software interface. Once the main interface appears, you will be able to access all operational controls and settings.

Setting Up for Cutting

Before beginning the cutting process, ensure the machine is properly set up for the desired operation. This involves selecting the correct cutting mode, adjusting parameters, and securing the workpiece.

1. Select the Cutting Mode:

- **Automatic Mode:** Choose this mode for fully automated operation, where the machine will control the movement and cutting process based on pre-set parameters.
- **Manual Mode:** Choose this mode if you wish to control the movement and cutting speed manually using the handwheel.

2. Adjust the Y-Axis Position and Cutting Speed:

- Use the software interface to adjust the **Y-axis position** to the desired starting point. This determines where the cutting will begin and how deep the blade will cut.
- Set the **cutting speed** according to the material and desired cut quality. The cutting speed (measured in mm/s) can be adjusted between 0-10mm/s in both automatic and manual modes.

3. Secure the Workpiece:

- Ensure the workpiece is firmly held in place using the appropriate **clamping vices**. Depending on the material and cutting requirements, you may use the **Fast Cam Locking Vise, Vertical Clamping Vise**, or other fixture options.
- Confirm that the material is securely positioned and aligned with the cutting path to avoid any unwanted movement during the cutting process.

Operating in Automatic Mode

When operating the machine in automatic mode, the system will handle most of the cutting process. The operator's role is to monitor the machine's performance and make adjustments as needed.

1. Press START:

Once the setup is complete, press the **START** button on the interface to begin the cutting operation. The machine will automatically start moving the blade and will begin cutting based on the pre-set parameters.

2. Blade Movement:

- The machine will automatically move the blade along the **Y-axis**, adjusting according to the cutting speed and feed rate.
- The system will continuously monitor the cutting progress, making any required adjustments to optimize the process.

3. Monitor Cutting Progress:

- On the software interface, you will see a **cutting progress bar** or percentage indicator that shows how much of the cutting process has been completed.
- The interface also displays real-time data on the Y-position, cutting speed, and feed rate, allowing you to track the operation's status and adjust if necessary.

Operating in Manual Mode

Manual mode allows for more hands-on control, making it suitable for applications requiring operator intervention and finer adjustments during the cutting process.

1. Use the Handwheel for Blade Movement:

In manual mode, the operator uses the **handwheel** to move the blade forward or backward along the Y-axis at a constant speed. Rotate the handwheel to adjust the blade's movement through the material.

2. Adjust the Feed Rate:

- **Feed Rate Adjustment:** Manually adjust the feed rate to control the speed at which the material is fed into the cutting blade. The feed rate is adjustable from 0-10mm/s and should be set based on the material's hardness, thickness, and the desired cut quality.
- **Fine Control:** Use the handwheel and feed rate controls to carefully guide the cutting process, especially when precision cutting or cutting delicate materials.

Emergency Stop Procedures

Safety is paramount when operating the SMART CUT 6025 Auto, and the machine is equipped with an **emergency stop** feature to immediately halt operation if necessary.

• Press the Emergency Stop Button:

In the event of an emergency, press the **Emergency Stop Button** to immediately stop all operations. This will instantly halt the cutting process, disengage the blade, and power off the machine's control panel to prevent further action.

• Resetting the Machine:

After pressing the emergency stop, you will need to reset the machine to resume operations. Simply turn the emergency stop button back to its normal position to re-enable the machine. You can then restart the cutting process after ensuring that the situation has been resolved.

Adjusting Cutting Parameters

During both automatic and manual operation, adjustments to certain cutting parameters may be necessary to optimize the cutting process based on the material being cut or changes in the operation.

- **Adjust Cutting Speed:**
The cutting speed may need to be adjusted during the operation to achieve the best cut quality or avoid excessive heat buildup. Use the software interface to increase or decrease the speed within the allowable range (0-10mm/s). Slower speeds are often required for harder materials, while faster speeds can be used for softer materials.
- **Adjust Feed Rate:**
The feed rate determines how quickly the material is fed into the blade. In automatic mode, the system controls the feed rate, but in manual mode, you have direct control. Adjust the feed rate to match the material thickness, cutting depth, and desired finish.
- **Y-Axis Positioning:**
The Y-axis position determines the cutting depth and the starting point for the cut. If the cut needs to be adjusted, you can fine-tune the Y-axis position using the software interface. For deeper cuts, move the Y-axis down accordingly; for more shallow cuts, adjust the position upwards.
- **Monitor Progress:**
Continuously monitor the software interface to ensure the cutting process remains within the desired parameters. If the cut is not progressing as expected, pause the machine and adjust the cutting speed, feed rate, or blade position.

5. Maintenance and Care

Maintaining your **SMART CUT® 6025-A** is essential to ensuring its longevity, performance, and reliability. Regular maintenance prevents costly repairs, optimizes cutting performance, and improves safety during operation. Below are the key maintenance areas that require attention to keep your machine in excellent working condition.

Regular Maintenance Schedule

Regular maintenance ensures the machine continues to operate efficiently and safely. Following a consistent schedule will help prevent unexpected issues during operation.

- **Inspection Frequency:**
Inspect and clean the machine after every **50 hours** of operation. This helps ensure optimal performance, reduces the accumulation of dust and debris, and keeps components in good condition.
- **Check Blade Alignment:**
After every 50 hours of use, check the blade alignment to ensure it is positioned correctly for precise cutting. Misaligned blades can lead to inaccurate cuts, excessive wear, or damage to both the blade and the machine. Align the blade according to the manufacturer's specifications.

- **Blade Condition:**
Inspect the blade for signs of wear, cracks, or other damage. Replace the blade if it shows signs of dullness or if it has become damaged. A dull or damaged blade can lead to poor cutting results and cause unnecessary strain on the motor and other components.
- **Lubrication Check:**
Depending on the machine's design and use, inspect the lubrication of key moving parts (e.g., the spindle and feed mechanisms). Apply lubricant if needed to ensure smooth and efficient operation.

Cleaning Instructions

Cleaning your machine regularly is essential to prevent the build-up of dust, cutting debris, and coolant residues. This not only keeps the machine functioning at its best but also reduces the risk of contamination and corrosion.



- **Turn Off and Unplug the Machine:**
Always turn off and unplug the machine before cleaning to ensure your safety. Allow the machine to cool down before cleaning, especially after extended cutting sessions.

- **Wipe Down the Machine:**
Use a soft, clean cloth to wipe down the exterior and interior of the machine, removing dust, debris, and any other buildup. Avoid using rough or abrasive materials, as these can scratch or damage the machine's surface.
- **Cleaning the Cutting Area:**
Pay particular attention to the cutting area, including the blade, work table, and clamps. Dust and cutting debris can accumulate and interfere with the machine's performance. A vacuum with a soft nozzle or an air compressor can help remove any excess material that may have collected in hard-to-reach areas.
- **Avoid Harsh Chemicals:**
Do not use harsh chemicals, abrasive cleaners, or solvents that could damage the machine's components, especially those made of aluminum, plastic, or sensitive electronics. Instead, use mild detergents or machine-specific cleaning solutions recommended by the manufacturer.
- **Coolant Cleaning:**
If your machine uses coolant, it is essential to clean the coolant system to prevent the build-up of contaminants. A clogged or dirty coolant system can reduce the effectiveness of cooling and increase the risk of overheating. Regularly inspect and flush the coolant system to ensure proper flow and cooling performance.

Blade Maintenance and Replacement

The cutting blade is one of the most critical components of your **SMART CUT® 6025-A**. Proper blade maintenance and replacement are essential to ensure clean, accurate cuts and prevent damage to the machine.



- **Blade Sharpening or Replacement:**

If the blade becomes dull or loses its cutting efficiency, it should either be sharpened or replaced, depending on the extent of wear. A dull blade can lead to uneven cuts, longer cutting times, and greater heat buildup, which can damage both the blade and the material being cut.

 - **Sharpening:** If the blade is designed for sharpening, use the appropriate sharpening tools and techniques recommended by the manufacturer. Ensure the blade is restored to the correct cutting profile.
 - **Replacement:** If the blade shows significant wear, cracks, or damage, replace it with a new one. Always use the correct replacement blade specified for your machine's cutting needs.
- **Proper Blade Alignment:**

Before beginning any cutting process, ensure the blade is correctly aligned. Misalignment can cause poor cutting performance, excessive vibration, and premature wear. Blade alignment should be checked periodically, especially after blade replacement or sharpening.
- **Checking Blade Tension (If Applicable):**

Some blades, particularly band saw blades, require tensioning to operate efficiently. Check the tension as per the manufacturer's guidelines, and adjust it if necessary to avoid blade slipping or uneven cuts.

Cooling System Care

The cooling system plays a critical role in preventing overheating during cutting, which can degrade both the blade and the workpiece. Maintaining this system ensures consistent performance and helps extend the life of your machine and its components.

- **Check Coolant Level:**
Regularly check the coolant level in the machine's reservoir. Low coolant levels can cause the machine to overheat, reducing cutting efficiency and potentially damaging components. Top off the coolant as needed using the recommended type of coolant.
- **Coolant Quality:**
Over time, coolant can degrade due to contamination and the accumulation of metal shavings or dust. If the coolant appears cloudy or has a strange odor, it may need to be replaced. Always use the recommended coolant type for your machine to ensure effective heat dissipation and lubrication.
- **Cleaning the Coolant System:**
Periodically clean the coolant system to remove debris, rust, or other contaminants that may have built up. This helps maintain efficient coolant flow and ensures the system operates effectively. Follow the manufacturer's guidelines for draining, cleaning, and refilling the coolant system.
- **Inspecting Coolant Lines and Pumps:**
Check the coolant lines and pump for leaks, cracks, or blockages. A damaged line or pump can lead to inefficient cooling and affect the machine's performance. Repair or replace any faulty parts promptly to avoid further damage.

Additional Maintenance Tips

- **Check All Moving Parts:**
Inspect the machine's moving parts, including the Y-axis, spindle, and feed mechanisms. Apply lubricant or grease to reduce friction and wear on these components.
- **Electrical and Control System Maintenance:**
Periodically check the electrical connections and control panel for signs of wear, corrosion, or loose connections. Tighten any loose connections, and ensure all electrical components are functioning properly.
- **Regular Calibration:**
Over time, the machine may experience slight shifts in its alignment or settings. Regularly calibrate the machine to ensure cutting accuracy and precision. Calibration should be done as per the manufacturer's instructions or after significant blade replacements or repairs.

Types of Vices and Their Uses

1. Fast Cam Locking Vises

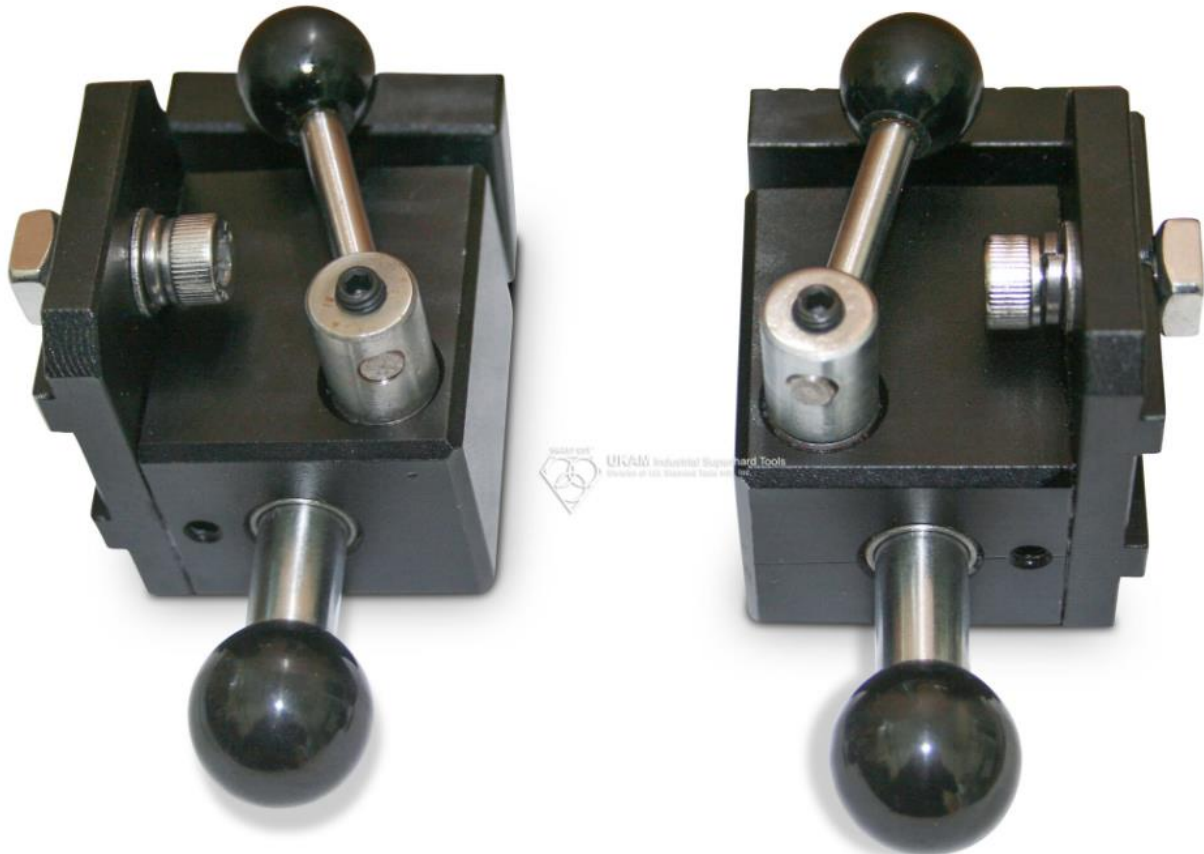

Fast Cam Locking Vises are designed for quick and secure clamping of materials. They use a cam mechanism to rapidly lock or release the workpiece, making them ideal for tasks that require frequent setup changes.

Uses:

- **Quick Setup and Removal:** The primary benefit of this type of vice is its ability to clamp and release the material quickly. This is especially useful in high-volume or repetitive cutting operations.
- **Handling Multiple Materials:** These vices are versatile and can be used for a variety of materials, including metals, plastics, and composites.
- **Ideal for Non-Delicate Materials:** They provide a strong grip but may not be suitable for fragile or delicate materials that could be damaged by excessive clamping force.

Advantages:

- Speedy setup and clamping.
- Reliable and secure clamping force.
- Minimal tool change time.

2. Vertical Clamping Vise

A Vertical Clamping Vise holds materials in a vertical orientation. This type of vise is commonly used in precision cutting operations where the material must remain fixed while the blade moves horizontally.

Uses:

- **Precision Cutting:** It ensures that the material remains perfectly aligned during the cutting process, making it suitable for high-precision tasks such as PCB cutting or material slicing for semiconductor applications.
- **Ideal for Thin or Delicate Materials:** Vertical vices are often used to hold thin materials like foils, wafers, or thin ceramic sheets without distorting or damaging them.
- **Longitudinal Cutting:** Particularly effective when cutting along the length of a material, such as bars or rods, which need to be securely fixed along their entire length.

Advantages:

- Accurate and stable clamping for precise cuts.
- Minimizes material distortion during cutting.
- Useful for materials requiring long, straight cuts.

3. X-Feed Fixture

An X-Feed Fixture is designed to facilitate movement of the material along the X-axis, typically when continuous or uniform feeding is required during the cutting process. This fixture helps in achieving controlled and consistent cutting.

Uses:

- **Automated Feed Control:** The fixture provides automated movement for materials fed into the cutting machine. This is ideal for applications where multiple materials are processed in succession.
- **High-Speed Cutting Applications:** In high-speed cutting scenarios, the X-Feed Fixture ensures that the material is consistently fed at the correct rate, contributing to improved efficiency and precision.
- **Material Shaping:** It is also used in shaping applications where the material needs to be progressively moved through the cutting area for uniform cutting depth or pattern.

Advantages:

- Consistent and controlled material movement.

- Enhanced productivity through automation.
- Reduced material handling errors.

4. Cutting Vice for Longitudinal Direction (Screws, Bars, etc.)

This specialized vice is designed for securely clamping cylindrical or long materials such as rods, bars, or screws. The vice holds the material in place while the blade cuts along the material's length.

Uses:

- **Longitudinal Cutting of Bars or Rods:** It is specifically designed for longitudinal cuts, making it ideal for cutting long and cylindrical materials, such as bars, pipes, and screws.
- **Precision Slicing of Thin Long Materials:** For materials like aluminum rods, stainless steel bars, or composite tubes, this vice ensures the material remains stable during the entire cutting process.
- **Handling Fragile Materials:** The adjustable clamps allow for precise and secure holding of materials without damaging or distorting them.

Advantages:

- Precision in longitudinal cuts.
- Stable holding of long materials.
- Prevents warping or twisting during the cutting process.

5. General Purpose Vices (Manual or Pneumatic)

General-purpose vices are often the most versatile type of vice, able to hold materials of various shapes and sizes. They come in both manual and pneumatic versions, depending on the need for manual force or automated handling.

Uses:

- **Versatility in Material Types:** General-purpose vices can hold a wide range of materials, from metal and plastics to ceramics and composites.
- **Suitable for Multi-Task Applications:** They can be used for general cutting, grinding, or even in some shaping operations, making them highly flexible.
- **Manual or Automatic Handling:** Depending on the design, these vices can either be manually clamped or connected to automated pneumatic systems for faster processing.

Advantages:

- Versatile and adaptable to a wide range of materials.
- Cost-effective for various tasks.
- Can be upgraded with pneumatic systems for automation.

Choosing the Right Vice for Your Application

When selecting a vice for your cutting operations, it's important to consider the following factors:

- **Material Type:** Ensure the vice is compatible with the material you are cutting, whether it is fragile, thick, or long.
- **Cutting Method:** Choose a vice based on whether you need vertical, longitudinal, or precise feed movements.
- **Precision Requirements:** For high-precision cutting, consider using a vertical clamping vice or a fast cam locking vice.
- **Frequency of Use:** For high-volume cutting or quick changes between setups, a fast cam locking vice or X-feed fixture will improve efficiency.
- **Material Size and Shape:** For long, cylindrical materials, a longitudinal cutting vice is ideal. For small, delicate materials, a vertical clamping vice will provide better support and accuracy.

TROUBLE SHOOTING GUIDE:

Malfunction	Possible Cause	Solution
No power or movement	A. The machine is not connected to the power supply.	A. Connect the power supply.
	B. The emergency stop button was pressed.	B. Release the emergency stop button.
	C. Power switch is in the off position.	C. Turn on the power switch.
	D. Electrical circuit failure or blown fuse.	D. Check the fuse and replace it if necessary.
Significant vibration during cutting	A. The cutting force is insufficient.	A. Lower the feed rate.
	B. The cutting piece is not suitable for the material.	B. Use the correct cutting piece for the material.
	C. The cutting speed is too high for the material being cut.	C. Reduce the cutting speed.
	D. The machine's base or mounting is unstable.	D. Ensure the machine is securely mounted on a stable surface.
Inconsistent cutting quality	A. The blade is dull or damaged.	A. Replace or sharpen the blade.
	B. Incorrect blade alignment.	B. Align the blade properly using the calibration tools.

Malfunction	Possible Cause	Solution
	C. Material is not securely fixed.	C. Ensure the material is properly clamped.
	D. Blade is not suitable for the material type.	D. Choose the appropriate blade for the material being cut.
Excessive noise during operation	A. Loose parts or components.	A. Tighten any loose components.
	B. Worn bearings or moving parts.	B. Replace the worn bearings or moving parts.
	C. Blade is rubbing against the material incorrectly.	C. Check the alignment and ensure the blade is correctly positioned.
Blade overheating	A. Insufficient cooling or lubrication.	A. Ensure the coolant system is functioning correctly or add more coolant.
	B. Cutting speed is too high for the material.	B. Reduce the cutting speed to prevent excessive heat generation.
	C. Blade material is incompatible with high-heat applications.	C. Use a blade specifically designed for high-heat resistance.
Inaccurate positioning of cuts	A. Misalignment of the X or Y-axis.	A. Check and calibrate the axis alignment.
	B. Software settings are incorrect.	B. Reconfigure the software settings for accuracy.
	C. Mechanical components are worn or damaged.	C. Inspect and replace worn mechanical components like gears or motors.
Error messages on display	A. Software malfunction or crash.	A. Restart the device and reload the software.
	B. Communication error between components.	B. Check all connections and restart the machine.
	C. Faulty sensor or input issue.	C. Inspect the sensors or input devices and recalibrate or replace them.
Loss of precision or accuracy	A. The blade is misaligned.	A. Realign the blade according to the manufacturer's specifications.
	B. Overheating during operation.	B. Improve cooling and reduce cutting speed.
	C. Wear and tear on key machine components.	C. Inspect and replace any worn-out parts such as the drive motors or bearings.
Excessive tool wear or breakage	A. Incorrect material or tool combination.	A. Ensure the correct tool is used for the material type.

Malfunction	Possible Cause	Solution
	B. Too high cutting speed or force.	B. Reduce the speed or force applied during cutting.
	C. Lack of proper maintenance on the tool.	C. Regularly inspect and maintain the tool for optimal performance.
Excessive cutting fluid consumption	A. Coolant system malfunction.	A. Inspect and repair the coolant system, ensuring no leaks or blockages.
	B. Incorrect cutting parameters causing excessive heat.	B. Adjust cutting speed and feed rate to prevent overheating and reduce fluid consumption.
Inconsistent feed rate	A. Feed motor malfunction.	A. Check and replace the feed motor if needed.
	B. Issues with the mechanical feed mechanism.	B. Inspect and lubricate the feed mechanism or replace worn parts.
	C. Software settings not configured for the material being cut.	C. Reconfigure feed rate settings in the software to match the material.